

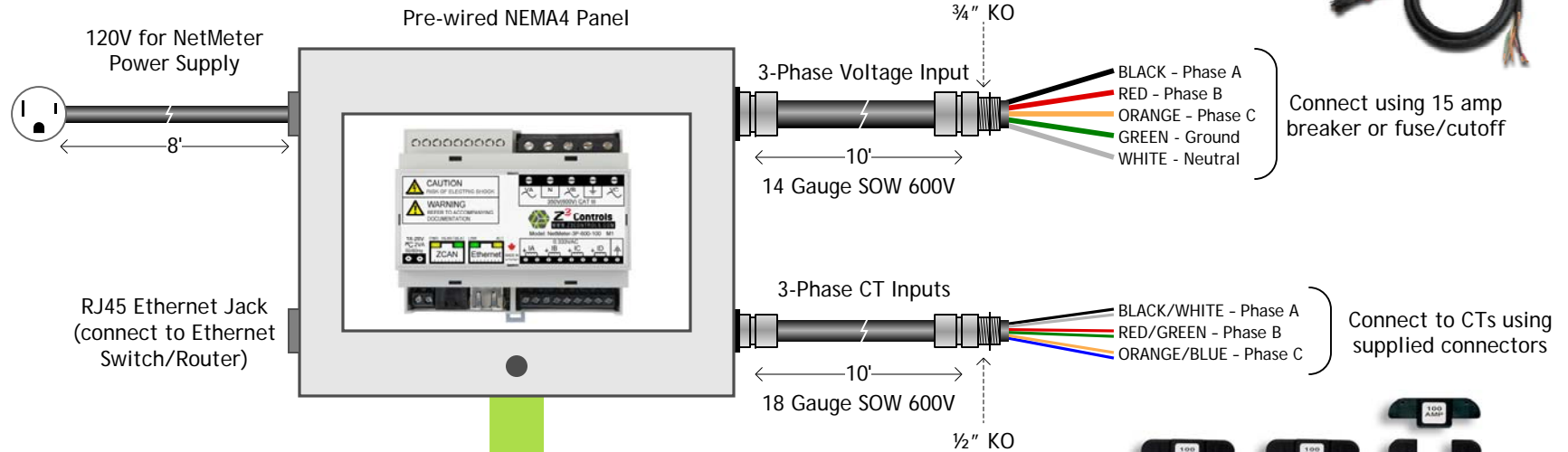

NetMeter Evaluation System Quick Guide



Split-core CT's

Chassis Schematic

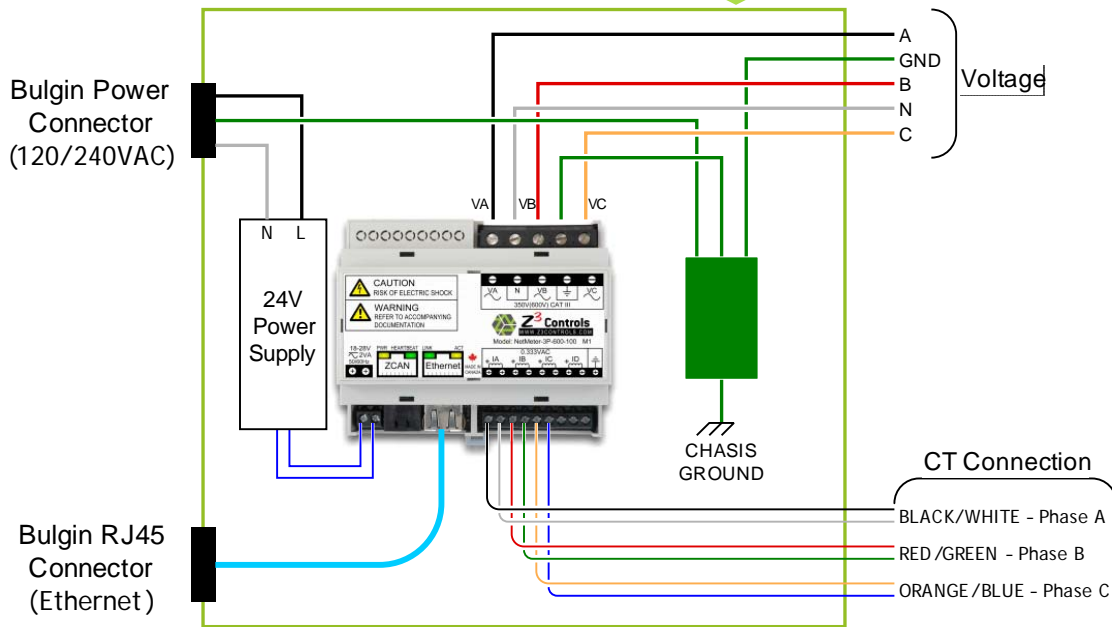

Installation Instructions

1. Read the NetMeter Installation Manual and follow safety procedures
2. Connect NetMeter Panel to load panel using the 3/4 and 1/2 knockouts for voltage and CT connections
3. Use 15 amp breaker or fuse/cutoff to supply 3 phase voltage
4. Connect voltages to the phases as documented in the above diagram
5. Open the supplied CTs and insert around load wires for each phase. The CTs are directional. Be sure to use the noted direction.
6. Plug each CT into its' corresponding phase so that CT for Phase A matches the voltage for Phase A and so on.
7. Close the load panel and re-energize when safe. Connect NetMeter power and provide Ethernet connection. Consult the Installation Manual for configuration and use of the NetMeter.